

Swichgage® Shutdown Panels for Irrigation Engines and Pumps

IR-03063B
Revised 04-06
Catalog Section 30
(00-02-0544)



75160 Series

- Ideal for Irrigation Engines
- Includes Loss of Pump Discharge Pressure and High Coolant Temperature Swichgage Instruments
- Model With Solenoid Fuel Shutoff Valve

Description

The 75160 series:

This Swichgage panel is specifically configured for irrigation engines and includes loss of pump discharge pressure Swichgage instrument. The panel is enclosed on top, bottom, and both ends. Mounting flanges extend on top and bottom. The back of the panel is open. Access holes are in the bottom.

75160: includes low oil pressure, high coolant temperature, low pump pressure Swichgage instruments, Magnetic Switch, and emergency stop button.

75160D: includes SV-series solenoid diesel fuel valve (specify voltage).

For diesel engines without shut-down solenoid in the injection pump, add a Murphy SV Series solenoid fuel shut-off valve or RP2300 Series rack pull solenoid.

Panel Kits Include:

- Low Lube Oil Pressure Swichgage instrument
- High Coolant/ Temperature Swichgage instrument
- 518PH Magnetic Switch.
- SV Series Solenoid Fuel Shutoff Valve.
- PB128S Emergency stop push button.

Specifications

Low Lube Oil Pressure Swichgage instrument:

- 0-100 psi (0-689 kPa) [0-6.89 bar]
- 1/8 NPT process connection

Low Pump Pressure Swichgage instrument:

- 0-150 psi (1.03 MPa) [10.34 bar]
- 1/8 NPT process connection

High Coolant Swichgage instrument:

- 130-250°F (54-121°C)
- 48 in. (1.2 m) capillary
- 1/2 NPT process connection

518PH Magnetic Switch:

12 or 24 volt (specify)

SV Series Solenoid Fuel Shutoff Valve:

12 or 24 volt (specify)

Shipping Weight: 8 lbs. 8 ozs. (3.9 kgs.)

Shipping Dimensions:

15.5 x 16 x 10.5 in. (394 x 406 x 267 mm).

Warranty

A limited warranty on materials and workmanship is given with this FW Murphy product. A copy of the warranty may be viewed or printed by going to www.fwmurphy.com/support/warranty.htm

Dimensions (all Models)

NOTE: This is a standard schematic. If non-standard components are specified, this schematic may not exactly reflect your panel.

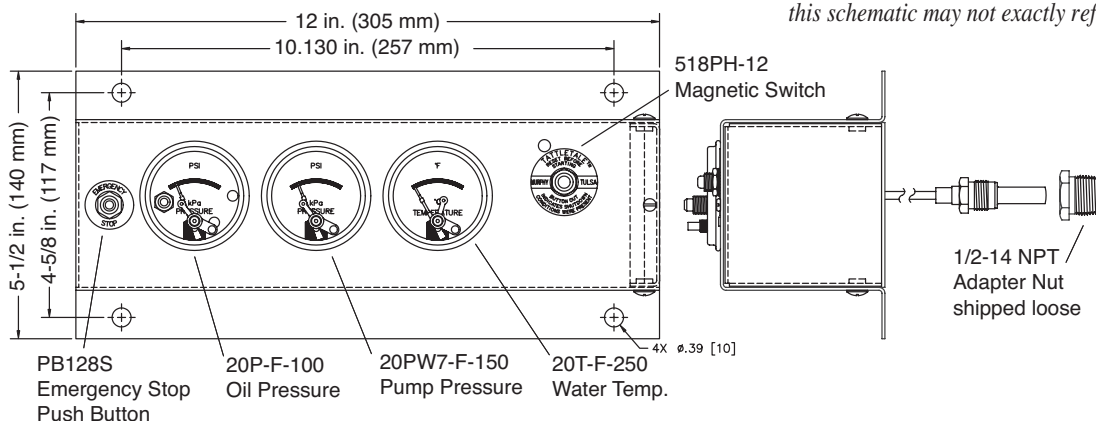

How to Order

NOTES:

1. * = Standard Component or Range and is not required for ordering, see section notes if section has two parts to specify.
2. If requirements are outside of the matrix, order panel with free formed text and use the '3050xxxx' product number of the base model.

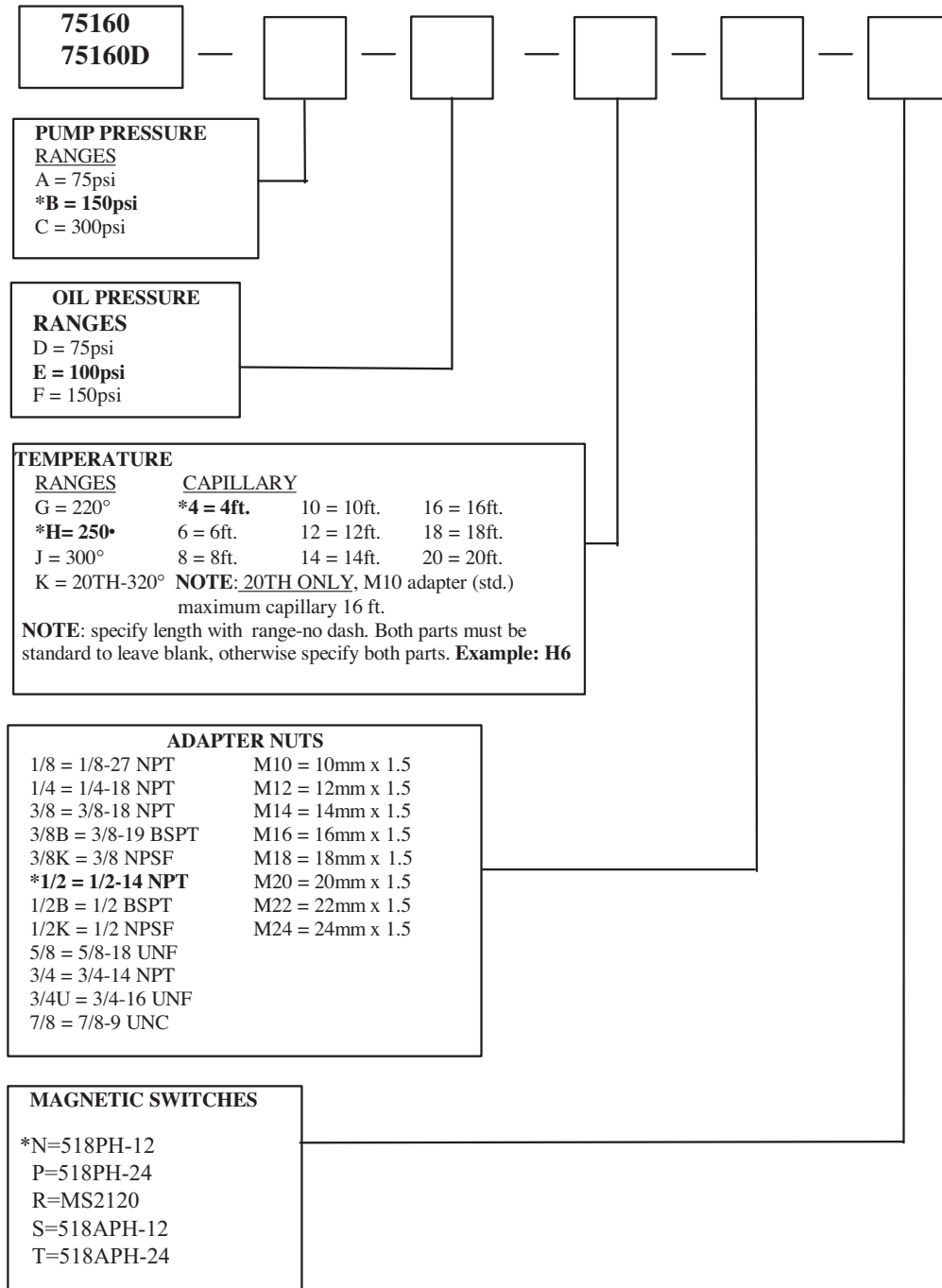

北京

信德迈科技(北京)有限公司 CNMEC Technology
地址：北京市朝阳区安贞桥胜古中路2号金基业大厦201室
邮编：100029
*Tel: 010-8428 2935 | * Fax: 010-8428 8762
*手机：139 1096 2635
*电子邮件：sales@cnmec.biz
主页：http://www.cnmec.com